



ACTIVE SPACE TECHNOLOGIES

OUR EXPERTISE

Space Sector

Key Clients: ESA, Airbus DS, OHB, Thales Alenia Space, Beyond Gravity, APCO, ONEWEB, ICEYE

Missions: Solar Orbiter, BepiColombo, EUCLID, ExoMars, JUICE, PLATO, HPCM, ARIEL, AWS

Large Research Facilities

- Key Clients: ITER, F4E, CERN, EFDA, Fusion for Energy, UK Atomic Energy Authority
- Partnering with some of the major LRF
- Expertise in Mechanical Design, Structural Analysis, Precision manufacturing of mechanical and electronic systems

Innovation Labs

Key Clients: Avio Aero, Leonardo, Safran, Thales

Projects: Additive Manufacturing, Power Systems

CORE CAPABILITIES

Mechanical Engineering

Design, Manufacturing, Prototyping, Assembly, Testing

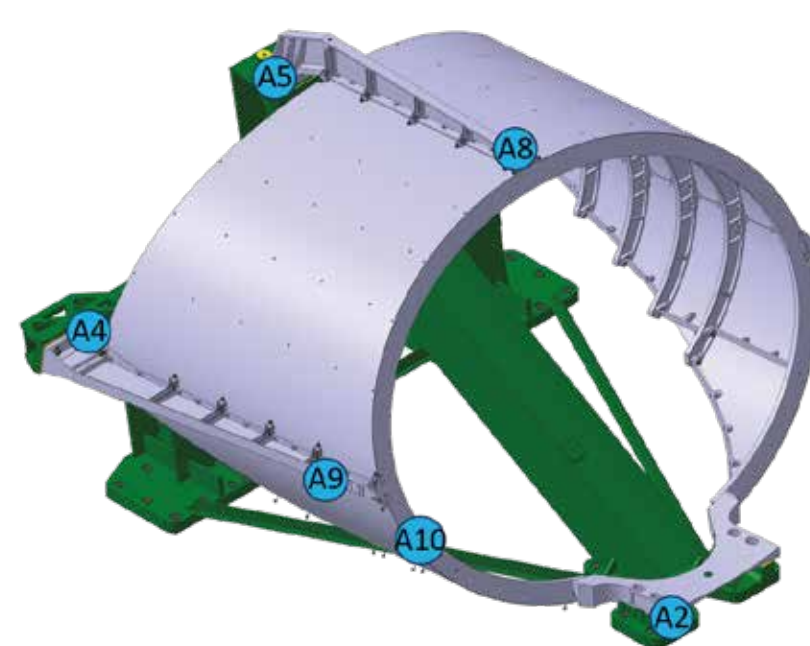

Electronics Engineering

PCB Manufacturing, Harnesses, Embedded Systems

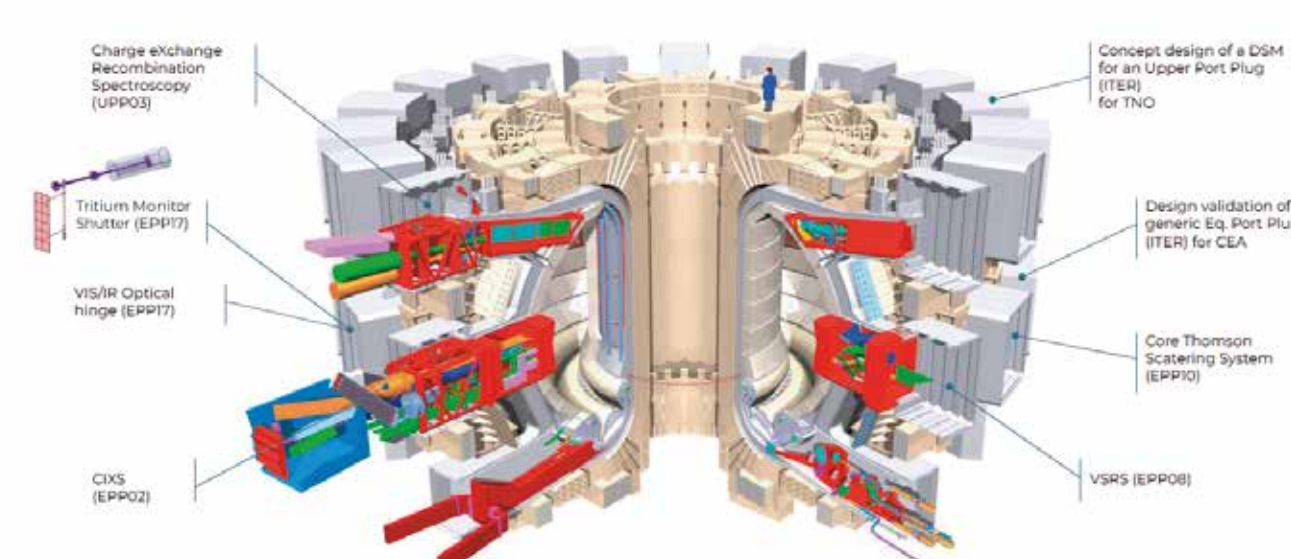

Environmental Testing

Thermal Vacuum Chambers, Vibration Testing, Cleanroom Assembly

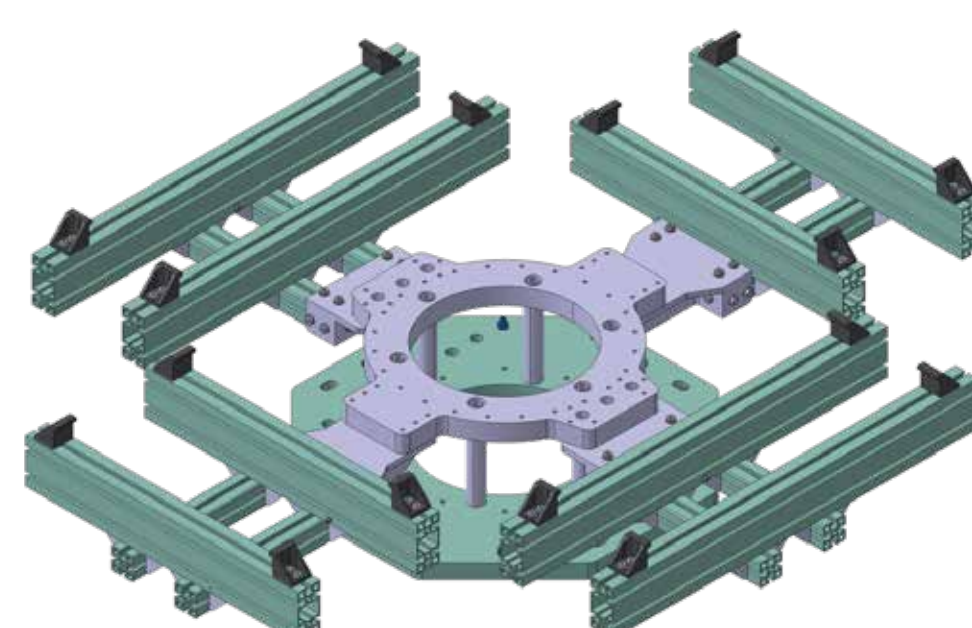

Our Commitment

Delivering precision-engineered solutions for the most challenging missions.

www.activespacetech.com

T: +351 304 505 505

@activespacetechnologies

@in/active-space-technologies